

APPLICATION NOTE

Urea

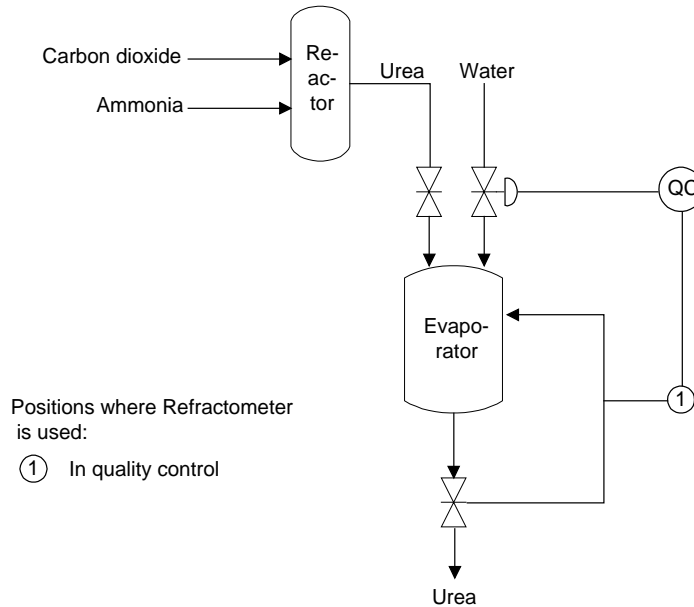

Urea NH_2CONH_2

Soluble in
water

Typical end products

Fertilizers, non-protein feed supplement for ruminants, manufacturing of urea-formaldehyde resins, plastics, adhesives, coatings, textile agents, ion-exchange resins

Chemical curve: R.I. per Conc% b.w.

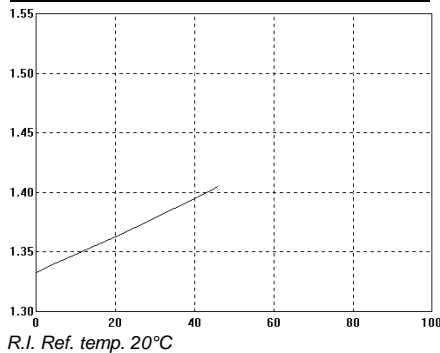

Introduction

Urea, NH_2CONH_2 , is a colourless crystal which dissolves in water. It is a weak base, and forms salts with strong acids. Urea is largely used as a fertilizer and as a non-protein feed supplement for ruminants. It is also used in the manufacturing of urea-formaldehyde resins, plastics, adhesives, coatings, textile agents, and ion-exchange resins.

Application

Urea can be made by numerous different methods, but commercially it is made by reacting carbon dioxide with ammonia at 200°C (392°F). After reaction urea is evaporated and produced to a final product in prilling or in granulating.

Installation

Refractometer is used as a quality control to measure the concentration of urea after reaction. Typical measurement range is 65-75% and the normal process temperature about 80°C (176°F).

Refractometer is used also to measure the concentration of dissolved urea in water in insulin (medicine) manufacturing.

Refractometer is installed in recirculation and used as a quality control to adjust the concentration of urea in water. Typical measurement range is 1.380-1.395 R.I. and the normal process temperature about 4°C (39°F).