

APPLICATION NOTE

Jam and Marmalade

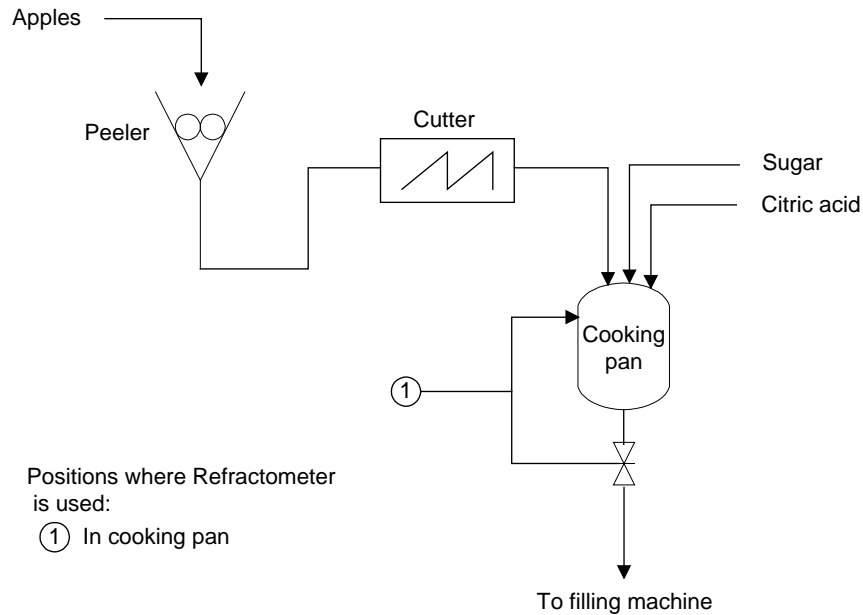

Jam, Marmalade

Chemical curve: R.I. per Brix

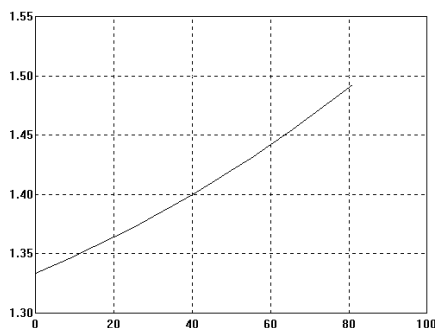

R.I. Ref. temp. 20°C

Introduction

Jam and marmalade are traditionally produced by the batch. The batch is controlled typically by laboratory samples. The need for automation and continuous on-line measurement has increased.

Application

Concentration measurement is used in jam and marmalade cooking pans to obtain a continuous reading of the product concentration and minimize the need of sugar.

Installation

Refractometer is used to measure the Brix level of the product in a by-pass line of the cooking pan or directly in pan.

Typical measurement range is 10-70 Brix (Jam cooking) and 50-85 Brix (Marmalade cooking), and the process temperature about 70-90°C (158-194°F).