

# APPLICATION NOTE

## Ethanol

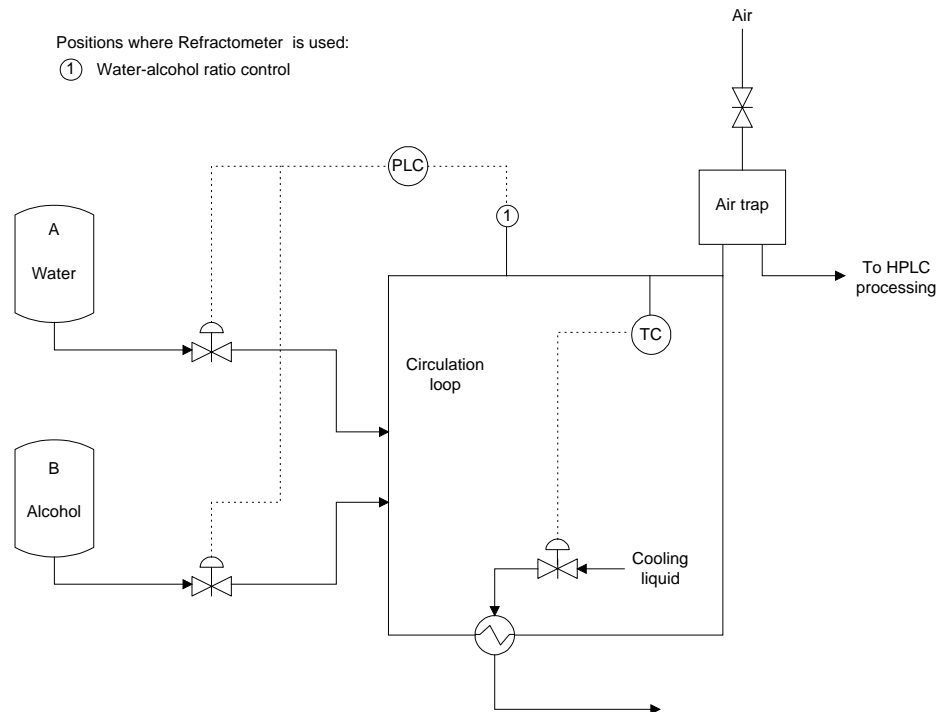

### Ethanol (C<sub>2</sub>H<sub>5</sub>OH), Ethyl Alcohol

Soluble in  
water

Typical end products  
alcohol, solvent, synthesis of chemicals, fuel

Chemical curve: R.I. per Conc% b.w.

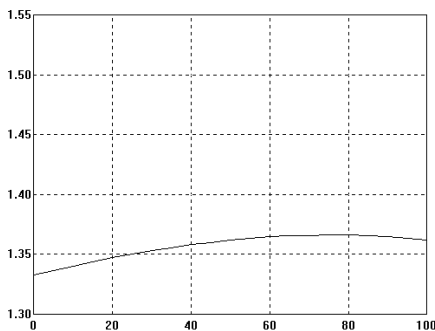

R.I. Ref. temp. 20°C

### Introduction

Ethanol (Ethyl Alcohol) is a colourless liquid and miscible with water with evolution of heat. Alcohol was formerly manufactured by the fermentation of materials containing starch and sugars.

At present most of the alcohol is made by the catalytic hydration of ethene. Ethanol is used as an alcohol or, much more widely, as a solvent and for synthesis of other chemicals or as a fuel.

### Application

In the pharmaceutical industry an alcohol and water mixture is used in HPLC (High Performance Liquid Chromatography).

The desired concentrations are obtained by mixing a full strength solution with water to achieve the

desired percent concentration. The alcohol and water mixture is kept at constant temperature about 15°C (59°F) by a plate cooler.

### Installation

Refractometer is used to control and measure the concentration of alcohol in water.

Typical measurement range is 0-50% and the normal process temperature is about 15°C (59°F).